

36 kV 250 A  
Heat Shrinkable Bushing

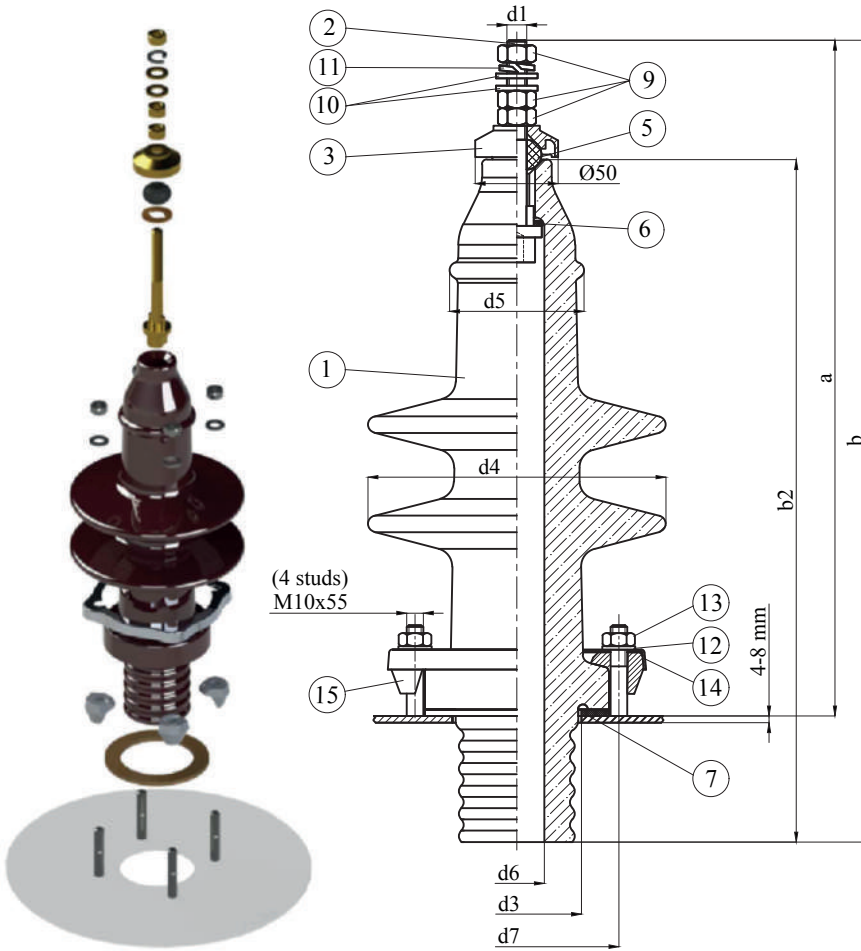

Insulation Levels acc. to IEC 60137:2017		
1	Highest Voltage (kV)	36
2	Rated Current (A)	250
3	Lightning Impulse Withstand Voltage (BIL) (kV)	170
4	Power Frequency Withstand Voltage (kV)	dry 77 wet 70
5	Creepage Distance (mm)	450
6	Rated Thermal Short-time Current (2s) (kA)	4,42
7	Rated Dynamic Current (kA)	15,63
8	Minimum Cantilever Withstand Load (N)	1000

15	4	Alu-Clamping
14	1	Fixing Ring
13	4	Nut DIN 934
12	4	Washer DIN 125
11	1	Spring Washer DIN 127
10	2	Brass Washer DIN 125
9	3	Brass Nut DIN 934
7	1	Gasket
6	1	IT Gasket
5	1	O-Ring
3	1	Brass Cap
2	1	Brass Bolt
1	1	Porcelain
POS.	PCS.	DESCRIPTION

\*\*\*All dimensions are "mm"

Type	a	b	b2	d1	d3	d4	d5	d6 min	d7	Weight (-kg)
30Nf / 250A 450mm	414	492	412	M12x1,75	78	180	81	33	123	6